



NOWE PRODUKTY

ZAWORY SILNIKOWE



OFERTA

**ENGINE VALVES | КЛАПАНЫ |
VENTILE SOUPAPES | VALVULAS |
SUPAPLAR**

NOWE PRODUKTY OFERTA

ZAWORY SILNIKOWE													
Kod produktu	Indeks AMP	Cena detaliczna netto	OEM	Kod EAN	Marka	Kod silnika	Model	Średnica trzonka	Średnica grzybka	Długość	Kąt przyłgni	IN / EX	Typ Zamka
8688	PBMW048-S-0-N	20,06 zł	11347583777	5903293630129	BMW	N52 B30 B, N20 B20 A, N55 B30 A	BMW 2.0 16V/3.0 24V	5,00	32,00	104,90	45°	IN	9,00
8689	PBMW049-B-0-N	28,55 zł	11347598273	5903293630136	BMW	N52 B30 B, N20 B20 A, N55 B30 A	BMW 2.0 16V/3.0 24V	6,00	28,00	112,80	45°	EX	9,00
8614	PCIT105-S-0-N	20,67 zł	9676359080	5903293628690	CITROEN	HNZ (EB2DT); HMZ (EB2), HMZ (EB2F), HMT (EB2D); ZMZ (EB0); HMU (EB2D), HMU (EB2FD); HMZ (EB2), HMZ (EB2F)	BERLINGO Furgon/minivan (B9) PureTech 110; C1 II (PA_, PS_) 1.2 VTI 82; C3 II (SC_) 1.0 VTI 68; C4 CACTUS 1.2 Vti; DS3 (SA_) 1.2 VTI 82	5,00	29,10	92,60	45°	IN	1,00
8615	PCIT106-A-0-N	21,56 zł	9676359180	5903293628737	CITROEN	HNZ (EB2DT); HMZ (EB2), HMZ (EB2F), HMT (EB2D); ZMZ (EB0); HMU (EB2D), HMU (EB2FD); HMZ (EB2), HMZ (EB2F)	BERLINGO Furgon/minivan (B9) PureTech 110; C1 II (PA_, PS_) 1.2 VTI 82; C3 II (SC_) 1.0 VTI 68; C4 CACTUS 1.2 Vti; DS3 (SA_) 1.2 VTI 82	5,00	26,00	91,90	45°	EX	1,00
8650	PCIT107-S-0-N	16,24 zł	9676718180	5903293629154	CITROEN	AHR (DW10FD); AHR (DW10FD); 4HT (DW12BTED4); 4HT (DW12BTED4); 4HP (DW12BTED4), 4HR (DW12BTED4)	C4 II (NC_) 2.0 HDi / BlueHDi 150; C5 III (RD_) 2.0 HDi 150 / BlueHDi 150; C5 II (RC_) 2.2 HDi; C6 (TD_) 2.2 HDi, C8 (EA_, EB_) 2.2 HDi; C5 II (RC_) 2.2 HDi	6,00	27,20	96,00	45°	IN	9,00
8651	PCIT108-B-0-N	25,41 zł	0949.E1	5903293629215	CITROEN	AHR (DW10FD); AHR (DW10FD); 4HT (DW12BTED4); 4HT (DW12BTED4); 4HP (DW12BTED4), 4HR (DW12BTED4)	C4 II (NC_) 2.0 HDi / BlueHDi 150; C5 III (RD_) 2.0 HDi 150 / BlueHDi 150; C5 II (RC_) 2.2 HDi; C6 (TD_) 2.2 HDi, C8 (EA_, EB_) 2.2 HDi; C5 II (RC_) 2.2 HDi	6,00	25,10	95,00	45°	EX	9,00
8616	PFIA317-S-0-N	38,02 zł	4802204	5903293628775	FIAT	8060.24.001; 8060.24.601; 8065.24 Turbo; 8060.24.670, 8060.24.671; 8060.24.678	FIAT 5.5TD - Series 80-16, Series 315.8.17; Series 115.17.1/135-17.1; 1280-1380	8,00	44,50	125,60	30°	IN	1,00
8648	PFIA320-S-0-N	15,21 zł	6000616511	5903293629055	FIAT	R9M 413	Talento 1.6 D	6,00	23,50	104,40	45°	IN	9,00
8649	PFIA321-B-0-N	22,68 zł	6260500800	5903293629109	FIAT	R9M 413	Talento 1.6 D	6,00	23,40	104,10	45°	EX	9,00
8650	PFIA318-S-0-N	16,24 zł	9676718180	5903293629161	FIAT	4HT (DW12BTED4)	ULYSSE (179_) 2.2 D Multijet	6,00	27,20	96,00	45°	IN	9,00
8651	PFIA319-B-0-N	25,41 zł	0949.E1	5903293629222	FIAT	4HT (DW12BTED4)	ULYSSE (179_) 2.2 D Multijet	6,00	25,10	95,00	45°	EX	9,00
8642	PFOR190-A-0-N	22,43 zł	1096250	5903293628966	FORD	DOFA, DT24H; D2FA, F4FA; DT24N, DT24P; D2FE	Transit 2.4 TDDi; Transit 2.4 DI 16V; Transit 2.4 TD; Transit 2.4 TDDI 16V	7,00	31,30	122,20	30°	IN	9,00
8650	PFOR251-S-0-N	16,24 zł	9676718180	5903293629147	FORD	T7DB; T7DB; T7DB; T8DE; T8DE; T8DA; Q4WA	C-MAX II (DXA/CB7, DXA/CEU) 2.0 TDCi; FOCUS III 2.0 TDCi; GRAND C-MAX (DXA/CB7, DXA/CEU) 2.0 TDCi;	6,00	27,20	96,00	45°	IN	9,00
8651	PFOR252-B-0-N	25,41 zł	0949.E1	5903293629208	FORD	T7DB; T7DB; T7DB; T8DE; T8DE; T8DA; Q4WA	C-MAX II (DXA/CB7, DXA/CEU) 2.0 TDCi; FOCUS III 2.0 TDCi; GRAND C-MAX (DXA/CB7, DXA/CEU) 2.0 TDCi;	6,00	25,10	95,00	45°	EX	9,00

NOWE PRODUKTY OFERTA

ZAWORY SILNIKOWE														
Kod produktu	Indeks AMP	Cena detaliczna netto	OEM	Kod EAN	Marka	Kod silnika	Model	Średnica trzonka	Średnica grzybka	Długość	Kąt przyłgni	IN / EX	Typ Zamka	
8650	PFOR251-S-0-N	16,24 zł	9676718180	5903293629147	FORD	T7DB ; T7DB ; T7DB ; T8DE ; T8DE ; T8DA ; Q4WA	C-MAX II (DXA/CB7, DXA/CEU) 2.0 TDCi ; FOCUS III 2.0 TDCi ; GRAND C-MAX (DXA/CB7, DXA/CEU) 2.0 TDCi ;	6,00	27,20	96,00	45°	IN	9,00	
8651	PFOR252-B-0-N	25,41 zł	0949.E1	5903293629208	FORD	T7DB ; T7DB ; T7DB ; T8DE ; T8DE ; T8DA ; Q4WA	C-MAX II (DXA/CB7, DXA/CEU) 2.0 TDCi ; FOCUS III 2.0 TDCi ; GRAND C-MAX (DXA/CB7, DXA/CEU) 2.0 TDCi ;	6,00	25,10	95,00	45°	EX	9,00	
8680	PHON054-B-0-N	24,96 zł	06147-5AY-H00	5903293630068	HONDA	P10A2, P10A4	CIVIC X 1.0 VTEC	5,50	23,00	112,40	45°	EX	1,00	
8702	PHON053-S-0-N	18,95 zł	14711-5AY-H00	5903293630372	HONDA	P10A2, P10A4	CIVIC X 1.0 VTEC	5,50	28,00	109,40	45°	IN	1,00	
8645	PIVE031-A-0-N	29,80 zł	99433902	5903293629000	IVECO	8060.45S Euro 1 6000, 6010, 6020, 6030, 6040, 6045, 6052, 6070, 6110, 6120, 6130, 6140, 6150, 6203, 6700	120/130/135 E 23 EuroCargo, 150/170 E 23 EuroCargo, 260/280 E 23 EuroCargo, 130 E 24 EuroCargo	9,00	38,30	141,20	45°	EX	1,00	
6787	PJOH048-B-0-N	87,28 zł	R122035	5903293607985	JOHN DEERE	PowerTech Plus V8	JOHN DEERE - SERIES 9000/7700/7800	9,00	46,50	196,00	30°	IN/EX	1,00	
8650	PLAN102-S-0-N	16,24 zł	9676718180	5903293629178	LANCIA	4HT	PHEDRA (179_) 2.2 D Multijet (179.AXM1B, 179.AXP11, 179.BXM1B)	6,00	27,20	96,00	45°	IN	9,00	
8651	PLAN103-B-0-N	25,41 zł	0949.E1	5903293629239	LANCIA	4HT	PHEDRA (179_) 2.2 D Multijet (179.AXM1B, 179.AXP11, 179.BXM1B)	6,00	25,10	95,00	45°	EX	9,00	
8652	PMWM026-B-0-N	32,96 zł	brak numeru OE	5903293629260	M.W.M.	TD 226 B-3 ; TD 226 B-4 ; TD 226 B-6	M.W.M. TRACTORS	9,00	43,00	117,00	45°	EX	9,00	
8644	PMER031-S-0-N	17,00 zł	6680530301	5903293628980	MERCEDES-BENZ	OM 668.914 ; OM 668.940 ; OM 668.941 ; OM 668.942	Vaneo 1.7 CDI ; A 160 CDI (168), A 170 CDI (168) ; A 160 CDI (168) ; A 170 CDI (168)	6,00	29,60	105,20	45°	IN	9,00	
8645	PMER096-A-0-N	29,80 zł	99433902	5903293629017	MERCEDES-BENZ	OM 356.944 Euro 1	Series 1317	9,00	38,30	141,20	45°	EX	1,00	
8648	PMER120-S-0-N	15,21 zł	6000616511	5903293629062	MERCEDES-BENZ	OM 626.951	KLASA C (W205) C 180 BlueTEC / d (205.036)	6,00	23,50	104,40	45°	IN	9,00	
8649	PMER121-B-0-N	22,68 zł	6260500800	5903293629116	MERCEDES-BENZ	OM 626.951	KLASA C (W205) C 180 BlueTEC / d (205.036)	6,00	23,40	104,10	45°	EX	9,00	
8650	PMIT067-S-0-N	16,24 zł	9676718180	5903293629185	MITSUBISHI	4HK, 4HN	OUTLANDER II (CW_W) 2.2 DI-D 4WD	6,00	27,20	96,00	45°	IN	9,00	
8651	PMIT068-B-0-N	25,41 zł	0949.E1	5903293629246	MITSUBISHI	4HK, 4HN	OUTLANDER II (CW_W) 2.2 DI-D 4WD	6,00	25,10	95,00	45°	EX	9,00	
8682	PMIT026-S-0-N	17,34 zł	MD075925	5903293630105	MITSUBISHI	G32B	Colt 1.6, Mirage 1.6, Lancer 1.6, L300 1.6	8,00	38,00	103,50	45°	IN	1,00	
8648	PNIS150-S-0-N	15,21 zł	6000616511	5903293629079	NISSAN	R9M, R9N	QASHQAI / QASHQAI +2 I (J10, NJ10, JJ10E) 1.6 dCi, X-TRAIL III (T32_, T32R, T32RR) 1.7 dCi	6,00	23,50	104,40	45°	IN	9,00	
8649	PNIS151-B-0-N	22,68 zł	6260500800	5903293629123	NISSAN	R9M, R9N	QASHQAI / QASHQAI +2 I (J10, NJ10, JJ10E) 1.6 dCi, X-TRAIL III (T32_, T32R, T32RR) 1.7 dCi	6,00	23,40	104,10	45°	EX	9,00	
8614	POPE139-S-0-N	20,67 zł	9676359080	5903293628706	OPEL	B 12 XHL (EB2DT) ; D 12 XE (EB2FA), B 12 XE (EB2F)	CROSSLAND X / CROSSLAND (P17, P2QO) 1.2 (75) ; CROSSLAND X / CROSSLAND (P17, P2QO) 1.2 (75)	5,00	29,10	92,60	45°	IN	1,00	
8615	POPE140-A-0-N	21,56 zł	9676359180	5903293628744	OPEL	B 12 XHL (EB2DT) ; D 12 XE (EB2FA), B 12 XE (EB2F)	CROSSLAND X / CROSSLAND (P17, P2QO) 1.2 (75) ; CROSSLAND X / CROSSLAND (P17, P2QO) 1.2 (75)	5,00	26,00	91,90	45°	EX	1,00	

NOWE PRODUKTY OFERTA

ZAWORY SILNIKOWE														
Kod produktu	Indeks AMP	Cena detaliczna netto	OEM	Kod EAN	Marka	Kod silnika	Model	Średnica trzonka	Średnica grzybka	Długość	Kąt przyłgni	IN / EX	Typ Zamka	
8648	POPE141-S-0-N	15,21 zł	6000616511	5903293629086	OPEL	R9M 452	VIVARO B Furgon (X82) 1.6 CDTI	6,00	23,50	104,40	45°	IN	9,00	
8649	POPE142-B-0-N	22,68 zł	6260500800	5903293629130	OPEL	R9M 452	VIVARO B Furgon (X82) 1.6 CDTI	6,00	23,40	104,10	45°	EX	9,00	
8614	PPEU120-S-0-N	20,67 zł	9676359080	5903293628713	PEUGEOT	HMZ (EB2F), HMT (EB2D); ZMZ (EB0); HNZ (EB2DT), HNV (EB2DTM); XfV (ES9A)	108 1.2; 208 I (CA_, CC_) 1.0; 308 II (LB_, LP_, LW_, LH_, L3_) 1.2 THP 110; 407 (6D_) 3.0 (6DXFVJ)	5,00	29,10	92,60	45°	IN	1,00	
8615	PPEU121-A-0-N	21,56 zł	9676359180	5903293628751	PEUGEOT	HMZ (EB2F), HMT (EB2D); ZMZ (EB0); HNZ (EB2DT), HNV (EB2DTM); XfV (ES9A)	108 1.2; 208 I (CA_, CC_) 1.0; 308 II (LB_, LP_, LW_, LH_, L3_) 1.2 THP 110; 407 (6D_) 3.0 (6DXFVJ)	5,00	26,00	91,90	45°	EX	1,00	
8650	PPEU122-S-0-N	16,24 zł	9676718180	5903293629192	PEUGEOT	EHZ (DW10FC); EHZ (DW10FC); AHW (DW10FC); 4HT (DW12BTED4); 4HT (DW12BTED4); 4HT (DW12BTED4); 4HP (DW12BTED4)	308 II 2.0 GT BlueHdi 180; 508 II 2.0 BlueHdi 180; 508 I 2.0 BlueHdi 180; 407 2.2 Hdi 170; 607 2.2 Hdi; 807 2.2 Hdi; 407 2.2 Hdi	6,00	27,20	96,00	45°	IN	9,00	
8651	PPEU123-B-0-N	25,41 zł	0949.E1	5903293629253	PEUGEOT	EHZ (DW10FC); EHZ (DW10FC); AHW (DW10FC); 4HT (DW12BTED4); 4HT (DW12BTED4); 4HT (DW12BTED4); 4HP (DW12BTED4)	308 II 2.0 GT BlueHdi 180; 508 II 2.0 BlueHdi 180; 508 I 2.0 BlueHdi 180; 407 2.2 Hdi 170; 607 2.2 Hdi; 807 2.2 Hdi; 407 2.2 Hdi	6,00	25,10	95,00	45°	EX	9,00	
7906	PREN106-S-0-N	19,36 zł	13201-6894R	5903293621639	RENAULT	H4J 700; H4J 700	MEGANE III coupe (DZ0/1_) 1.4 TCe (DZ0F, DZ1V); SCÉNIC III (JZ0/1_) 1.4 16V (JZ0F, JZ1V)	5,00	29,60	101,30	45°	IN	1,00	
7907	PREN107-B-0-N	26,87 zł	13202-8778R	5903293621646	RENAULT	H4J 700; H4J 700	MEGANE III coupe (DZ0/1_) 1.4 TCe (DZ0F, DZ1V); SCÉNIC III (JZ0/1_) 1.4 16V (JZ0F, JZ1V)	5,50	25,60	102,40	45°	EX	1,00	
8648	PREN108-S-0-N	15,21 zł	6000616511	5903293629048	RENAULT	R9M 409, R9M 414, R9N 400, R9N 401, R9M 453	TALISMAN (LP_) 1.6 dCi 130, KADJAR (HA_, HL_) 1.6 dCi 130, SCÉNIC IV (J9_) 1.7 Blue dCi 150 (J9A7, J9A8), MEGANE IV liftback (B9A/M/N_) 1.6 dCi 165	6,00	23,50	104,40	45°	IN	9,00	
8649	PREN109-B-0-N	22,68 zł	6260500800	5903293629093	RENAULT	R9M 409, R9M 414, R9N 400, R9N 401, R9M 453	TALISMAN (LP_) 1.6 dCi 130, KADJAR (HA_, HL_) 1.6 dCi 130, SCÉNIC IV (J9_) 1.7 Blue dCi 150 (J9A7, J9A8), MEGANE IV liftback (B9A/M/N_) 1.6 dCi 165	6,00	23,40	104,10	45°	EX	9,00	
8614	PTOY123-S-0-N	20,67 zł	9676359080	5903293628720	TOYOTA	1KR-FE; 1KR-FE	AYGO (_B1_) 1.0 (KGB10_); YARIS (_P9_) 1.0 GPL (KSP90_)	5,00	29,10	92,60	45°	IN	1,00	
8615	PTOY124-A-0-N	21,56 zł	9676359180	5903293628768	TOYOTA	1KR-FE; 1KR-FE	AYGO (_B1_) 1.0 (KGB10_); YARIS (_P9_) 1.0 GPL (KSP90_)	5,00	26,00	91,90	45°	EX	1,00	

Sposób oznaczania zaworu numerem AMP®

Przykład oznaczenia **P VWG 035 - A - P - C**

- **P** oznacza „zawór”
- Litery **XYZ** odwołują się do marki pojazdu (np. **VWG** – oznacza Volkswagen Group)
- **PXYZ###** indeks odwołujący się do geometrii zaworu

NAZWA PODSTAWOWA	Rozszerzenie nazwy podstawowej np.: A - P - C		
P + 3 litery + 3 cyfry	Materiał - 1 litera	Stellit - 1 litera lub cyfra "0"	Uszlachetnienie powierzchni - 1 litera lub cyfra "0"
Przykład: P VWG 035	S bez stellitu	0 bez stellitu	0 bez uszlachetniania
	A austenityczny	P stelitowana przylgnia	N azotowany
	B bimetaliczny	T stelitowany koniec trzonka	C chromowany
	Z zgrzewana płytka	W bez stellitu	D dogniatany



Typy zamków

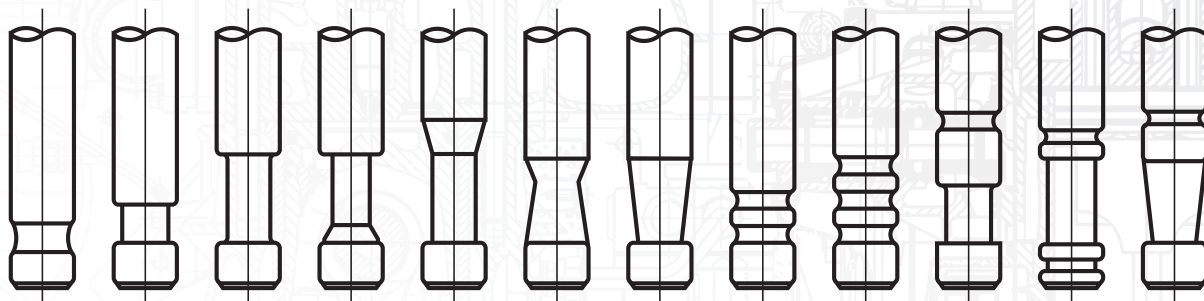

1 2 3 4 5 6 7 8 9 10 11 12

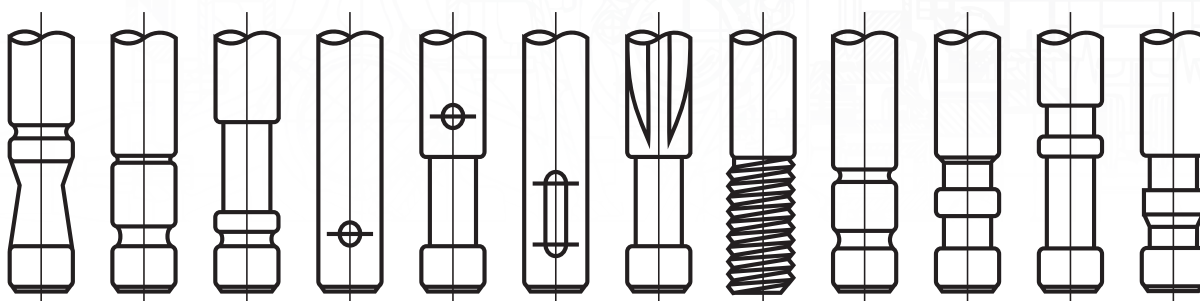

13 14 15 16 17 18 19 20 21 22 23 24

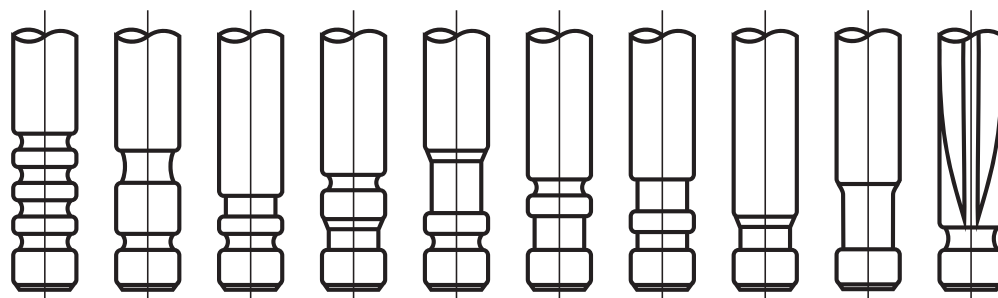

25 26 27 28 29 30 31 32 33 34

